

MDC151 - 012301 Brushless Speed Controllers



FEATURES

- **Maximum Current Limit Setting from 10.0- 30.0Amps (Peak)**
- **Internal or External Voltage Speed Control**
- **0V to 5V External Voltage Speed Control**
- **2-Quadrant Operation**
- **Hall Sensor Feedback**
- **Constant Velocity Mode**
- **Short Circuit Protection**
- **Requires 10-15 VDC**
- **Run/Stop, Freewheel and Direction Inputs**
- **TTL-CMOS Compatible Inputs**
- **Dual Mounting Option**
- **CE Certified and RoHS Compliant**



DESCRIPTION

The MDC151-012301 driver is designed to drive DC brushless motors at currents of up to 30A (peak) and 15V. Using hall sensor feedback, a constant velocity mode can be selected. The driver is protected against over current (cycle-by-cycle or latched), hall sensor error and under voltage. When an error occurs, a fault light notifies the user. If the fault latch is enabled and an error occurs, the fault output goes low to notify the user. Included on the driver is an internal potentiometer to control the maximum phase current allowed into the motor and an internal potentiometer to control the speed of the motor. An external voltage (0-5VDC) can be used to control the speed as well. The direction of the motor can be preset by the direction control input.

Other inputs to the drive include a run/stop and a motor freewheel input. When using the run/stop input, there are three ramp up/down profiles from standstill to select from. The run/stop input overrides all other inputs into the driver.

Ideal Applications

Automated machinery or processes that involve food, cosmetic, or medical packaging, labeling, or tamper-evident requirements, cut-to-length applications, electronic assembly, robotics, factory automation, special filming and projection effects, medical diagnostics, inspection and security devices, conveyor and material handling systems, metal fabrication (CNC machinery), pump flow control, XY and rotary tables, equipment upgrades or wherever precise positioning or speed control is required.

DIMENSIONS

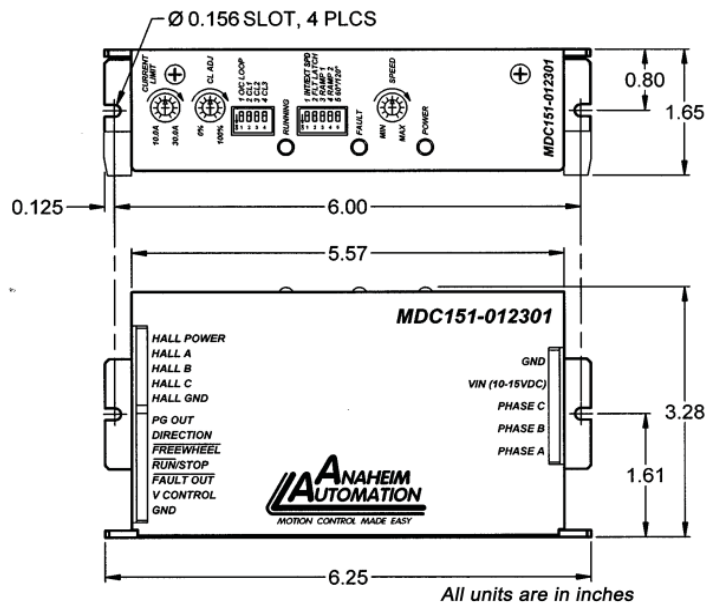

L010414

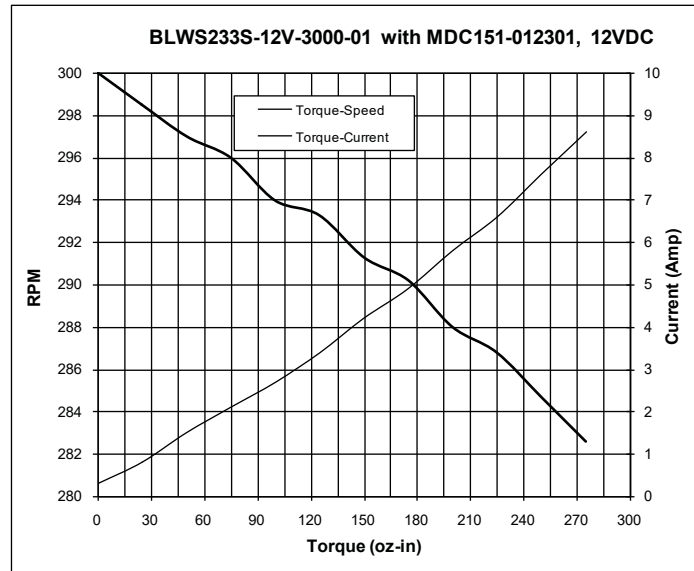

Control Inputs: (TB3, Pins 2-4)	TTL-CMOS compatible Logic "0" = 0 - 0.8VDC Logic "1" = Open
Direction Control: (TB3, Pin 2)	Logic "1" (open) - Clockwise Logic "0" - Counterclockwise
Freewheel: (TB3, Pin 3)	Logic "1" (open) - Motor is Enabled Logic "0" - Motor is de-energized and coast
Run/Stop: (TB3, Pin 4)	Logic "1" (open) - Motor will not run and if running, will come to a hard stop Logic "0" - Motor will run and will accelerate to ramp dip switch setting
V Control: (TB3, Pin 6)	To control the speed of the motor with an external DC voltage, INT/EXT SPD switch (SW1-POS1) must be switched to the ON position. 0VDC (min) - 5VDC (max)
Control Outputs: (TB3, Pin 1)	TTL-CMOS Compatible These outputs are able to sink 50mA.
PG: (TB3, Pin 1)	A 5V signal pulse out is available at a rate of 4 pulses for 1 revolution of an 8-pole motor, 3 pulses for 1 revolution of a 6-pole motor, and 2 pulses for 1 revolution of a 4-pole motor. 8-pole motor RPM = 15 * PG OUT in Hz 6-pole motor RPM = 20 * PG OUT in Hz 4-pole motor RPM = 30 * PG OUT in Hz
Fault Output: (TB3, Pin 5) <i>Enabled when fault latch is enabled.</i>	Logic "1" (5V Out) - Status good, normal operation. Logic "0" - One of the three fault conditions listed in the 'Fault Protect' section has occurred. When a fault is detected, the Fault Output (P in 5) goes low.
Maximum Closed Loop Motor Speed	2 pole: 30,000 RPM 4 pole: 15,000 RPM 6 pole: 11,250 RPM 8 pole: 7,500 RPM
Maximum Open Loop Motor Speed	50,000 RPM

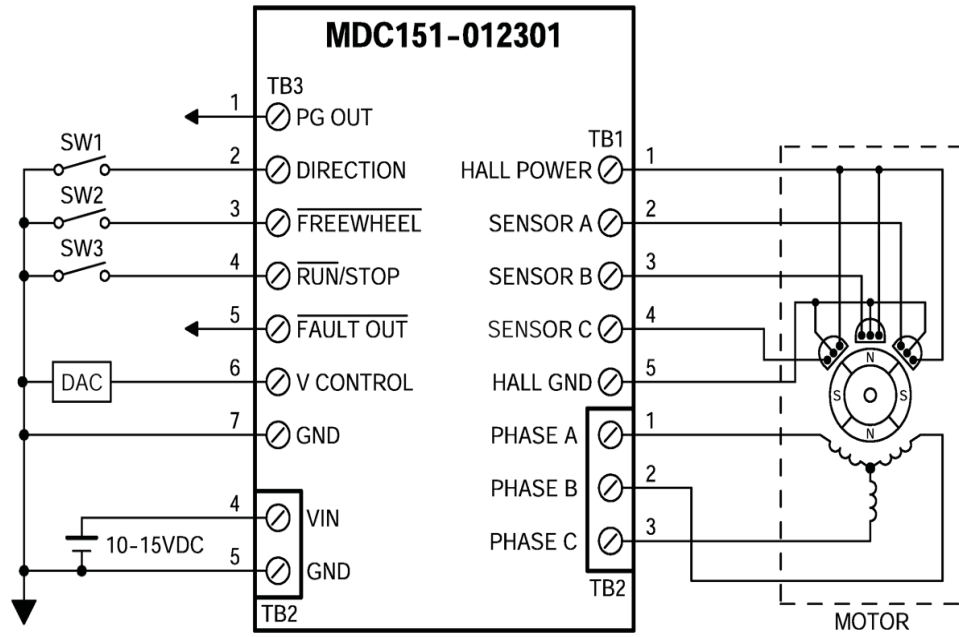

PG OUTPUT and FAULT OUTPUT

